



Transparent Wall Vent

INSTALLATION MANUAL



P.O. Box 279
Shakespeare, ON
NOB 2P0

1-800-960-4002
www.faromor.com

February 2014

Index

Page 3	Installation Instructions for Manual Vent Operator
Page 4	Rod Style Manual Vent Operator
Page 5-6	Installation Instructions for Rack and Pinion Hardware
Page 7	Framing Drawing for Rack and Pinion Wall Vent
Page 8	Double Gearbox with Powerhead drawing

Installation Instructions

Rod-Style Manual Vent Operator

1. Manual vent operator should be mounted such that it is centered in the middle of vent opening.
2. Galvanized steel angle is to be mounted along bottom edge of aluminum vent window, using 2 - #8 x 1" s.s. screws supplied.
3. Next, assembling vent operator (as shown in accompanying illustration) position rod adjustment bar on sill. Note that adjustment bar should be a minimum of 2" from edge of vent window frame. This will cause a slight bow in the galvanized rod, thus allowing the vent window to close tightly. The farther away the rod adjustment is from the window, the tighter the vent will close.
4. Mark off the most appropriate position for the rod adjustment along the sill, and proceed to screw bar into place, using 3 - #14 x 1-1/2" s.s. screws supplied.

Rod Style Manual Vent Operator

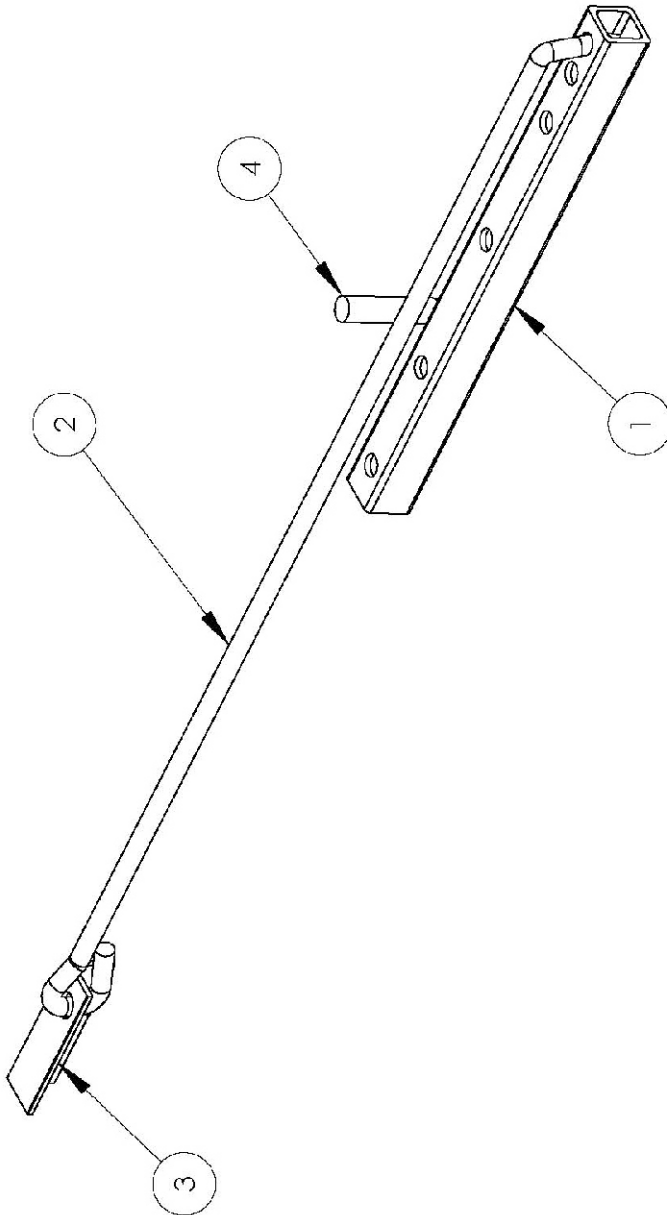

ITEM NO.	PART NUMBER	DESCRIPTION	QTY.
1	08-200-02-01	1" x 1" x 12" Steel Tube	1
2	08-200-02-02	3/8" dia. x 28" Rod	1
3	08-200-02-03	1"x1" x 3" Alum angle mount	1
4	08-200-02-04	1/2" x 2" Stop Rod Steel	1

TITLE: MANUAL VENT OPERATOR (rod style)		DATE: Apr/1993
PART/PROJECT#: 08-100-02		DRAWN BY: E.S.
REVISED: Dec/2008		SCALE: N.T.S.
		FILE:

FAROMOR
P.O. Box 279, RR#1
Shakespeare, Ontario
N0B 2P0 - (519) 625-8000

Installation Instructions

Rack and Pinion Hardware

It is recommended to use rack and pinion hardware for bottom hinged or bottom pivot vents. Standard linkage hardware has difficulty in maintaining a tight seal against the rubber seals due to torque in the rotating drive pipe.

1. Normally vents are fastened to the rough opening from outside the building prior to exterior cladding installation (Faromor vents are self-flashing). however, vents can be ordered for inside mounting which allow for self-flashing of the interior wall cladding.
2. Place vent in opening and fasten four corners assuring frame is placed squarely. A 1/4" tolerance is provided between opening and outer frame to permit alignment. use siding nails or screws to penetrate the frame without drilling. nailing pattern should be five (5) screws top and bottom and three (3) screws at each end (2 for 2 ft vent) with corner screws installed 3" from edge.
3. Assure top and bottom frame is levelled horizontally (a 3/8' plywood spacer is helpful during installation to assure outer frame is held level). An outer frame with a center deflection can prohibit vent from swinging freely.
4. To install the operating hardware begin by mounting the pipe hanger brackets 14' above the sill. note that two styles of hanger brackets are available - one for standard exterior mounted vents, and th alternate fro interior mounted vents. Pipe hanger brackets should be placed at each vent if distance between vents exceeds 8ft on center. Before proceeding with hanger bracket, refer to step #6 regarding mounting of gearbox.
5. Install the 1" diameter galvanized pipe by sliding through the pipe hanger brackets. Each pipe is joined to the next by use of pipe joiners. Do not forget to install the pinion and gearbox at appropriate location during this phase o installation. pinion are required at each vent - one per each linkage used. A 7 foot vent will operate okay with one centrally mounted rack although some customers choose to have on at each end. Longer vents should have the installation of two racks per vent.
6. The gearbox is mounted to a wall area that has been properly blocked during framing. It is usually located central to the section of vents it controls; however, it could be mounted at one end should it interfere with livestock, work alleys, etc. It is important that the gearbox be mounted so that its outshaft(s) is centered with the drive pipe. This can often be assisted by adjusting the position of pipe hanger brackets (closer or further from wall) at time of mounting. Fasten the drive pipe to gearbox by drilling a hole in the pipe and inserting a 5/16" bolt. Drill hole in one wall of pipe then align over the hole in shaft. Using the shaft as a drill guide, drill hole through second wall of pipe.

7. The aluminum rack is to be threaded through its respective pinion and mounted via the aluminum "T" or sash bracket to the top, or near the top of vent. Assure the rack shipped is correct length for the application. Cut to length on site if required. Grip the pinion bushing and rotate pushing the vent (via rack) to a tightly closed position. At the same time assure the pinion and rack are aligned with the "T" bracket mounted to vent. Now tighten the bushing via two (2) stainless set screws supplied.
8. If the system is manually operated, the gearbox will have been supplied with a crank handle. if automated, the gearbox will or can be fitted with an electric 24VDC motor. The drive motor mounts to the gearbox via an adjustable plate assembly.
9. A separate short rack and pinion are supplied with a limit switch attached. These are mounted next to the gearbox and motor, and electrically connected as show in wiring diagram. Mount the limit switch in an "OFF" (closed) position as the vents have been previously set in the closed position.
10. Power your system by electrically connecting as per schematic wiring diagram. The power panel may be located in the barn area or often in a nearby electrical utility room. It required a 110 VAC outlet only as it is supplied with a power cord. The thermostat is normally mounted close to the actuator and sensor wire positioned approximately 8 to 10 feet form the exterior wall, and as low as possible without being vulnerable to the livestock. Alternatively, you can locate your thermostat remotely from the actuator and extend the sensor wire up to 500 feet.

PARTS FOR LIMIT SWITCH ASSEMBLY:

	QTY:
BOX WITH BUSHING AND NUT	1
LID WITH SCREWS	1
SWITCH WITH CORRECT O-RING	2
PIECE OF 5-WIRE	1
8-32 BOLT (1/2") c/w NUT	2

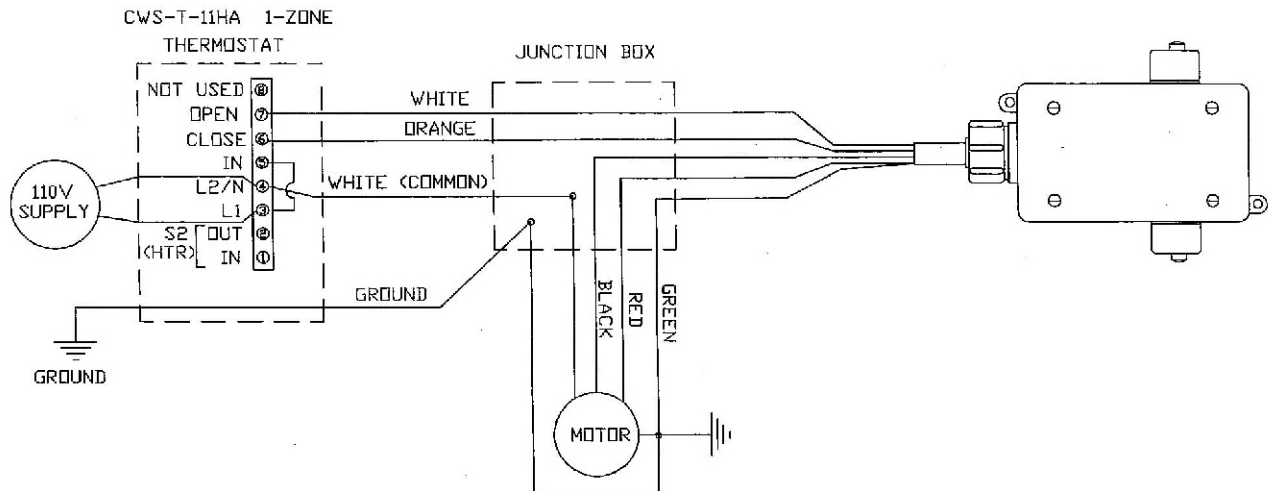
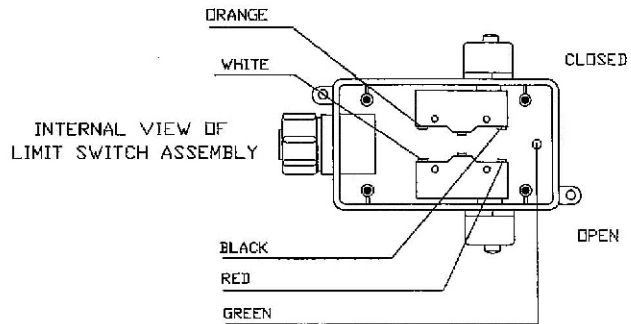

Framing Drawing Rack and Pinion Hardware

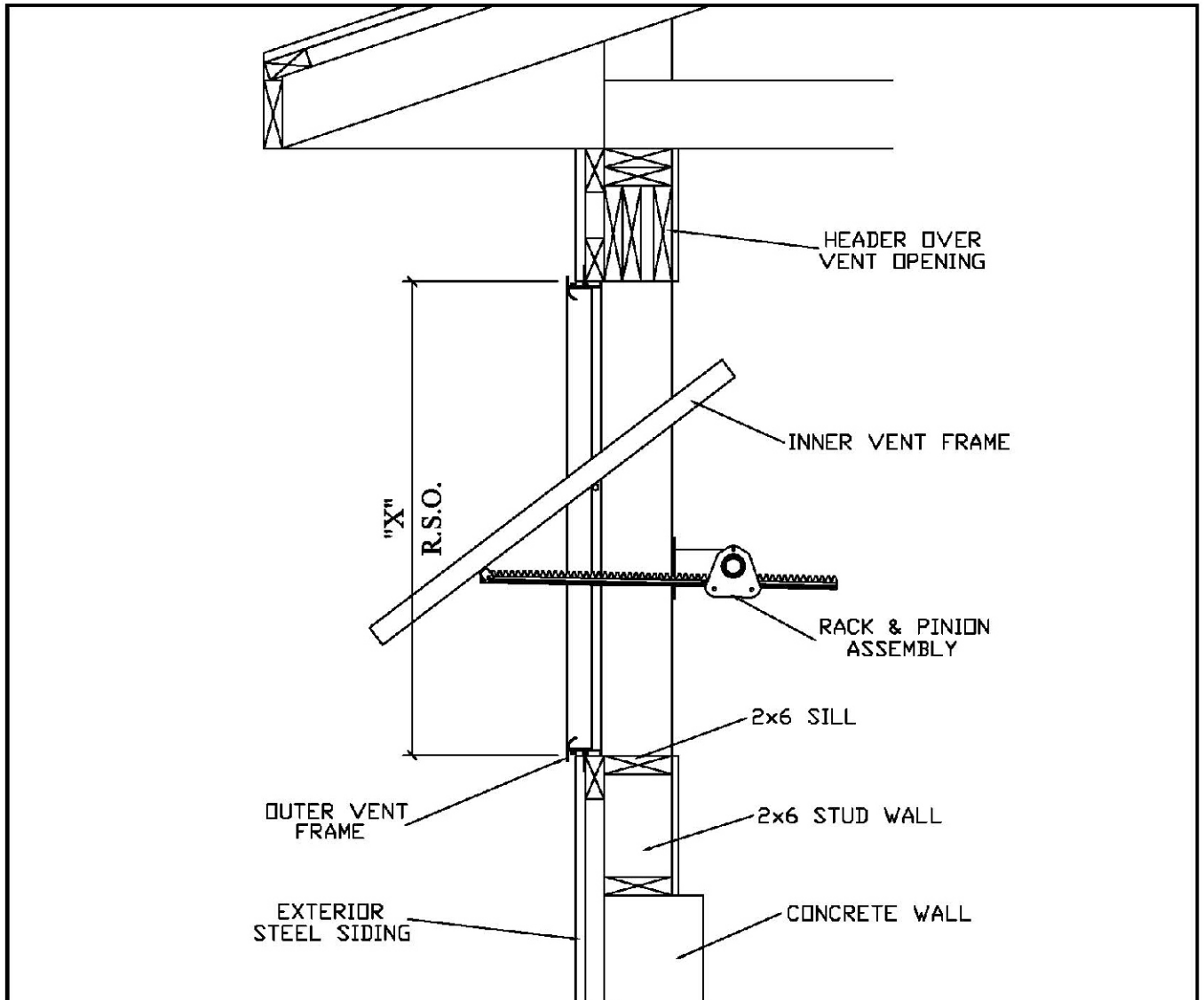

<u>FRAMING OPENING:</u>	
VENT SIZE:	R.S.O. ("X")
2' x 7'	26 1/4"H x 86 3/4"W
2' x 10'	26 1/4"H x 122 1/4"W
3' x 7'	38 1/4"H x 86 3/4"W
3' x 9'	38 1/4"H x 114 1/8"W
3' x 12'	38 1/4"H x 141 1/2"W

NOTES:
 ABOVE DETAILS FOR SALES PURPOSES ONLY.
 SEE DETAILED FRAMING DRAWINGS FOR
 MORE INFORMATION.
 CUSTOM SIZE VENTS AVAILABLE UPON REQUEST.

<b style="font-size: 2em;">FAROMOR P.O. Box 279, RR#1 Shakespeare, Ontario. NOB 2P0 - (519) 625-8000	TITLE: TILTING VENT WINDOWS	
	PROJECT / OWNER:	
	DRAWN: FEBRUARY 2004	DWG. FILE: 01-TILT VENT-W

Double Gearbox with Powerhead

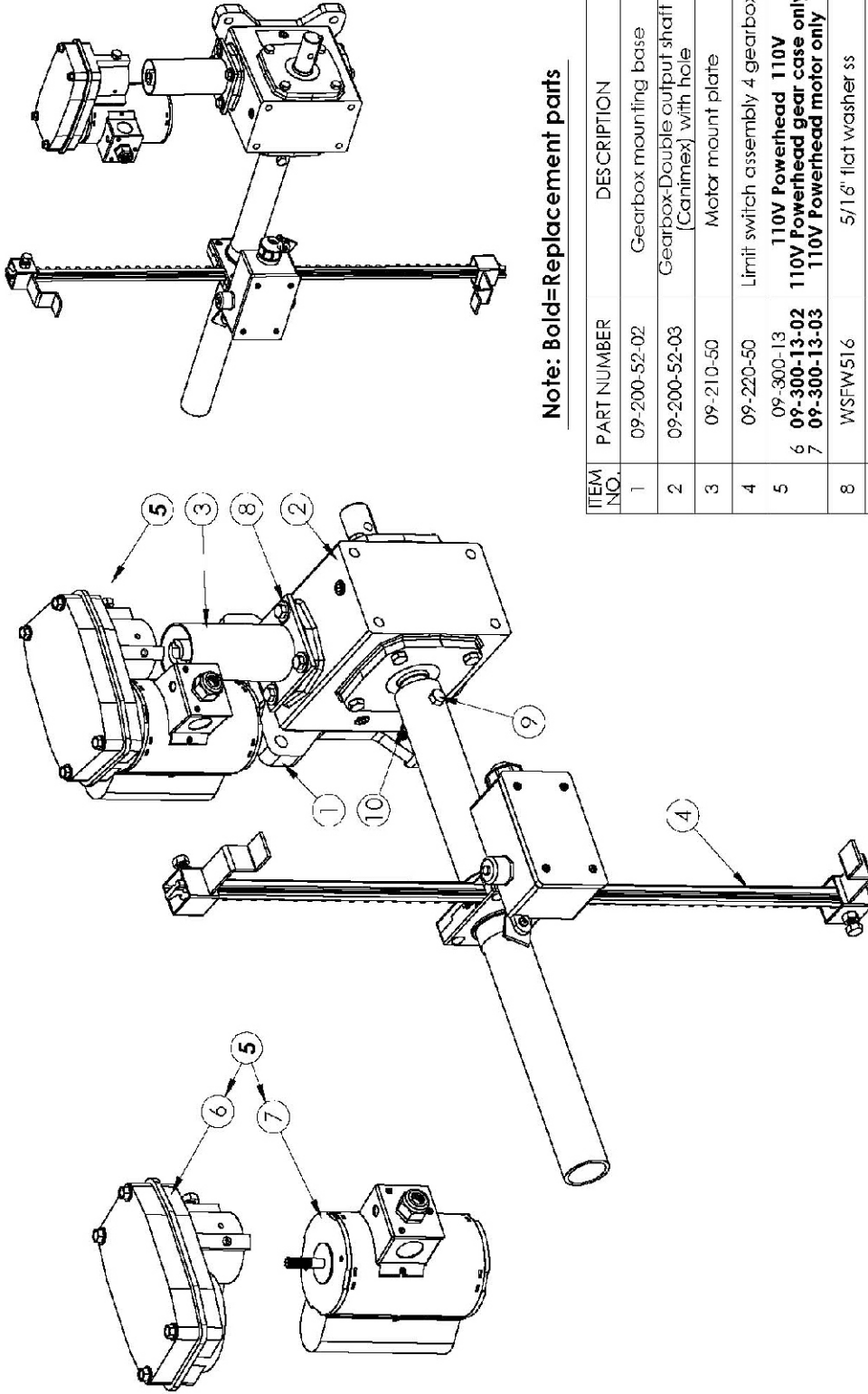

Note: Bold=Replacement parts

ITEM NO.	PART NUMBER	DESCRIPTION	QTY.
1	09-200-52-02	Gearbox mounting base	1
2	09-200-52-03	Gearbox-Double output shaft (Canimex) with hole	1
3	09-210-50	Motor mount plate	1
4	09-220-50	Limit switch assembly 4 gearbox	1
5	09-300-13	110V Powerhead 110V	1
6	09-300-13-02	110V Powerhead gear case only	1
7	09-300-13-03	110V Powerhead motor only	1
8	W5FW516	5/16" flat washer ss	4
9	B5HLB516212	5/16" x 2 1/2" hex lag bolt ss	1
10	NSRL516NEM	5/16"-18 ringlock NE/NM ss	1

FAROMOR

P.O. Box 279, RR#1
Shakespeare, Ontario,
N0B 2P0 - (519) 625-8000

TITLE: Double Gearbox with 110V Powerhead

PART/PROJECT#: 09-100-51

REVISED: March/29/2012

DATE: Nov/29/2010

DRAWN BY: E.S.

SCALE: N.T.S.

FILE:

PANEL SYSTEM SAFETY

NOTE: ALL INSTALLATION OF ELECTRICAL CONTROLS SHOULD BE DONE BY A QUALIFIED ELECTRICIAN.

General Operation

- Panels should only be operated when the owner or other responsible persons are in the facility.
- Unauthorized persons or small children should not be near or have access to the outside or inside automatic/manual drive units as they may result in injury. Do not attempt to stop any automatic drive unit by hand while it is in operation.
- Do not attempt to adjust cables or pulleys while system is in operation.
- When making adjustments to automatic drive units, ensure that the override switch is in the “off” position so that the curtain cannot start while any work is being completed.

Protective Covering

- Ensure that all drive units (manual or automatic) have the covers installed where applicable.
- Electrical motors mounted on outside of building should be covered to prevent damage.

PANEL SYSTEM MAINTENANCE

SOLAR/CLEAR VU/VIP

- All cables (main and pull-ups) should be checked on a monthly basis to ensure proper operation. Over time, some cables may stretch causing uneven pull up of panel system. Where necessary, loosen cable clamp, pull cable tight and re-fasten clamp when panel is level.
- Ensure all cable clamps are tightly secured so it does not result in drop cables coming loose.
- Check all pulleys for excess wear on wheels that may cause cable to get caught.
- Periodically check over aluminum panel joiners top and bottom to ensure they are fastened tightly.

NOTE: FOR ANY SERVICE ON THERMOSTATS OR AUTOMATIC DRIVE UNITS, PLEASE CONTACT A SERVICE REPRESENTATIVE FOR ASSISTANCE. FOR ADJUSTMENT OF LIMIT SWITCHES SEE INSTALLATION MANUALS – ELECTRICAL SECTION.

General Cleaning:

- Use mild soap or detergents for cleaning any of our Faromor products – do not use solvents or aggressive cleaning agents.
- High pressure washers can be used on all products but maintain a minimum distance from product of approximately 1m so as not to put too much pressure on the material – especially fabric curtains.
- Ensure rolling curtains are in the fully closed position when washing so that excess water does not get caught in the rolls of the fabric – allow the water to run completely off the curtains.
- Avoid direct pressure on any curtain area that has an existing hole or ClearVu panel that has an existing crack – the added water pressure may cause more damage at those locations.
- **FOR DRIVE UNITS** – it is recommended to do a simple hand cleaning of the units with warm water and avoid excess water around the motor, wiring or vent plugs so no water will enter the gears or damage the wiring – this will cause premature failure.

NOTE: DO NOT USE HIGH PRESSURE WASHERS OR WATER OF ANY KIND TO CLEAN DRIVE UNITS OR THERMOSTATS – THIS WILL DAMAGE THE UNITS.