



# ASSEMBLY INSTRUCTION / INSTRUCTIONS POUR ASSEMBLAGE

## NEED HELP?

Call or Email us first

## BESOIN D'AIDE?

Écrivez-nous ou appelez nous d'abord

Our service team is ready to answer your questions...

1-800-265-1833 (English) / 1-800-567-2513 (French)

IN CANADA - ressaiescanada@canarmna.ca - IN USA - ressaiesusa@canarmna.ca

Monday – Friday  
8 AM - 5 PM E.S.T.

Notre équipe de service est prêt à répondre à vos questions...

1-800-265-1833 (Anglais) / 1-800-567-2513 (Français)

Au Canada - ressaiescanada@canarmna.ca - Aux États-Unis - ressaiesusa@canarmna.ca

Lundi – Vendredi  
8 AM - 5 PM E.S.T.

## FLETCHER

Model / Modèle# 203522-02

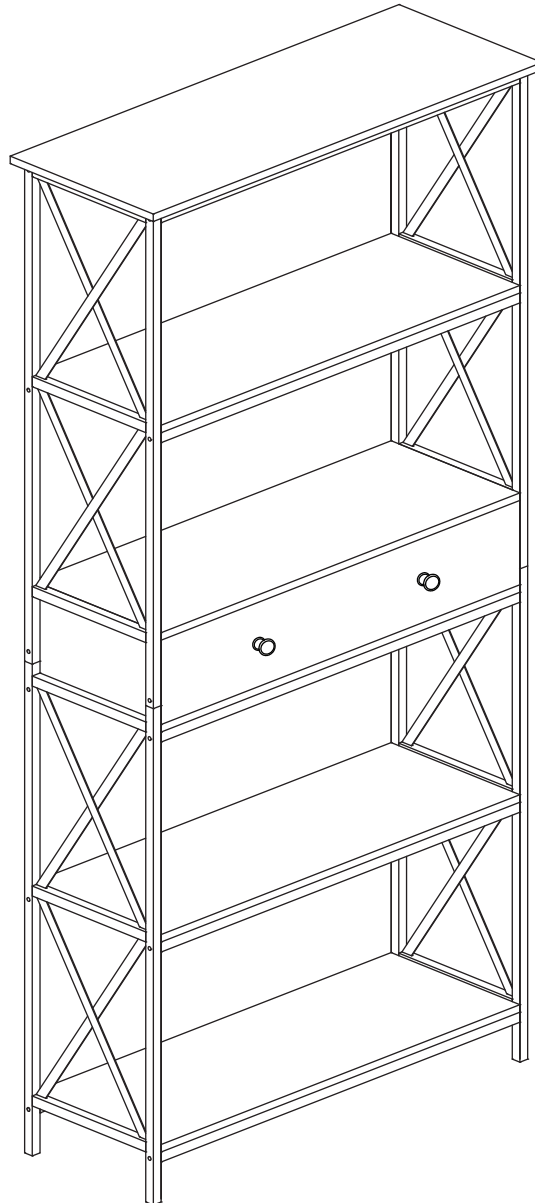

**Maximum  
weight capacity /  
Capacité de  
charge maximale:  
5KG per shelf /  
par tablette  
2KG for the drawer /  
pour les tiroirs**

### Cleaning and care

For regular maintenance of your furniture, use a soft cloth with a mild cleaning solution. Never use abrasives or harsh chemicals to clean the furniture as it may harm the finish. Indoor use only, avoid direct sunlight.

### Nettoyage et entretien

Pour l'entretien régulier de votre meuble, utilisez un chiffon doux avec une légère quantité de produit nettoyant. N'utilisez jamais d'abrasif ou de produits chimiques forts pour nettoyer le meuble puisque cela peut endommager le fini. Pour utilisation à l'intérieur seulement, évitez l'exposition directe au soleil.

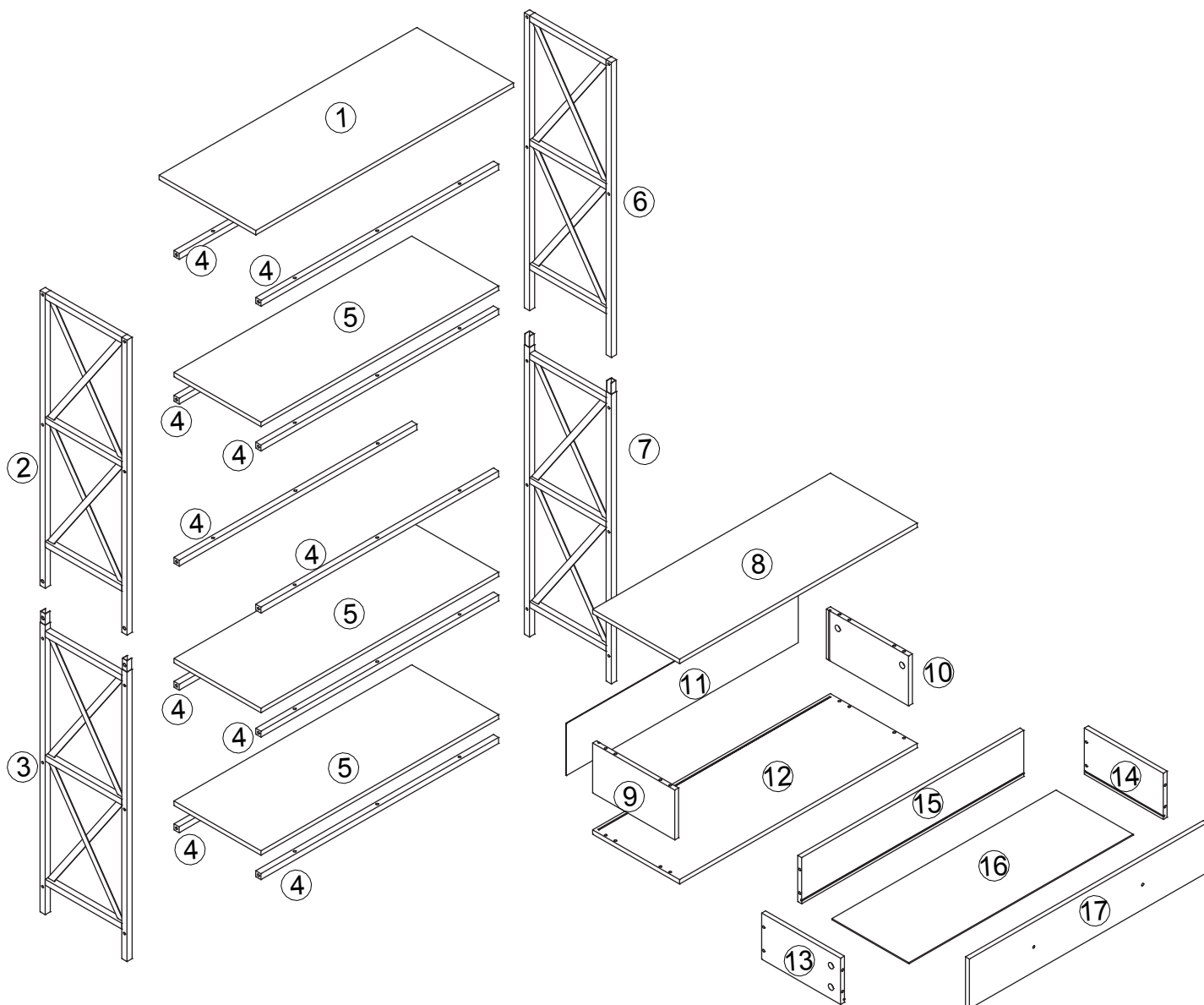

## HARDWARE INCLUDED / QUINCAILLERIE INCLUSE

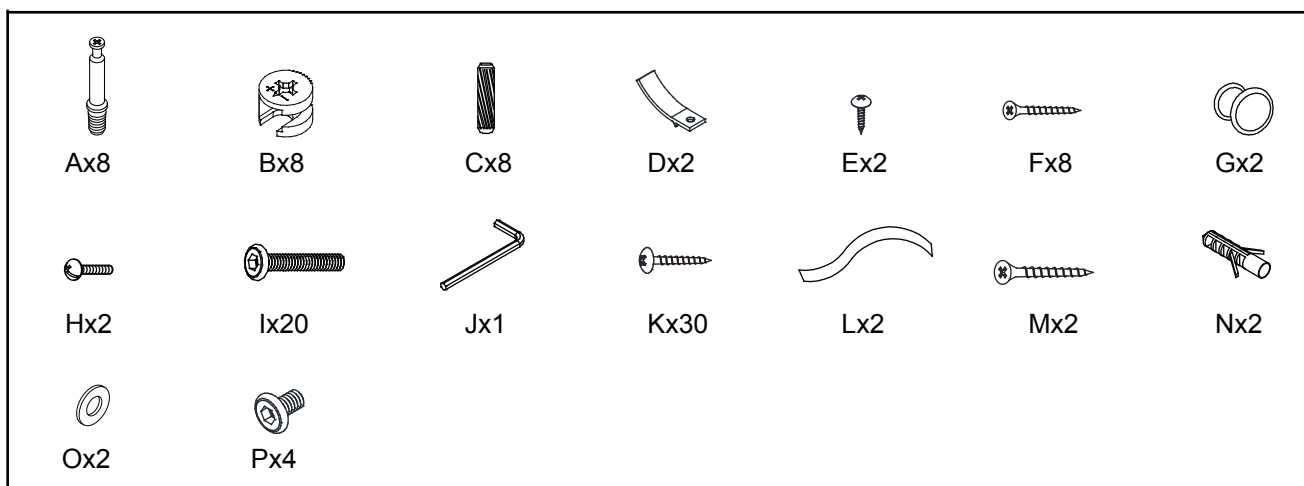

# Step 1 Étape 1

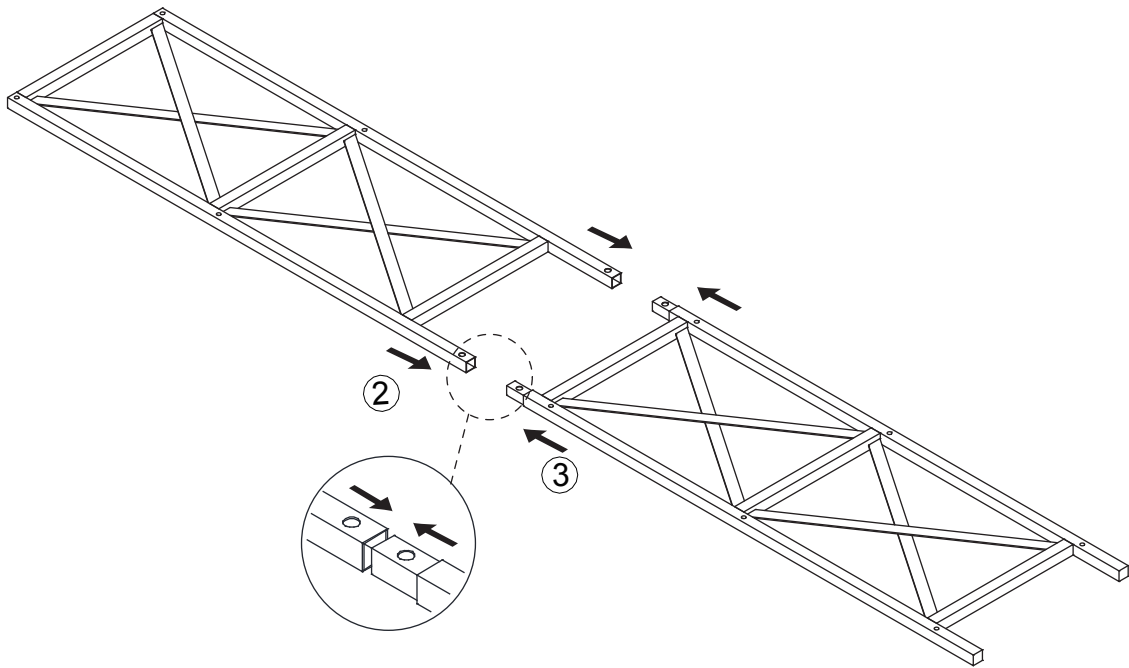

# Step 2 Étape 2

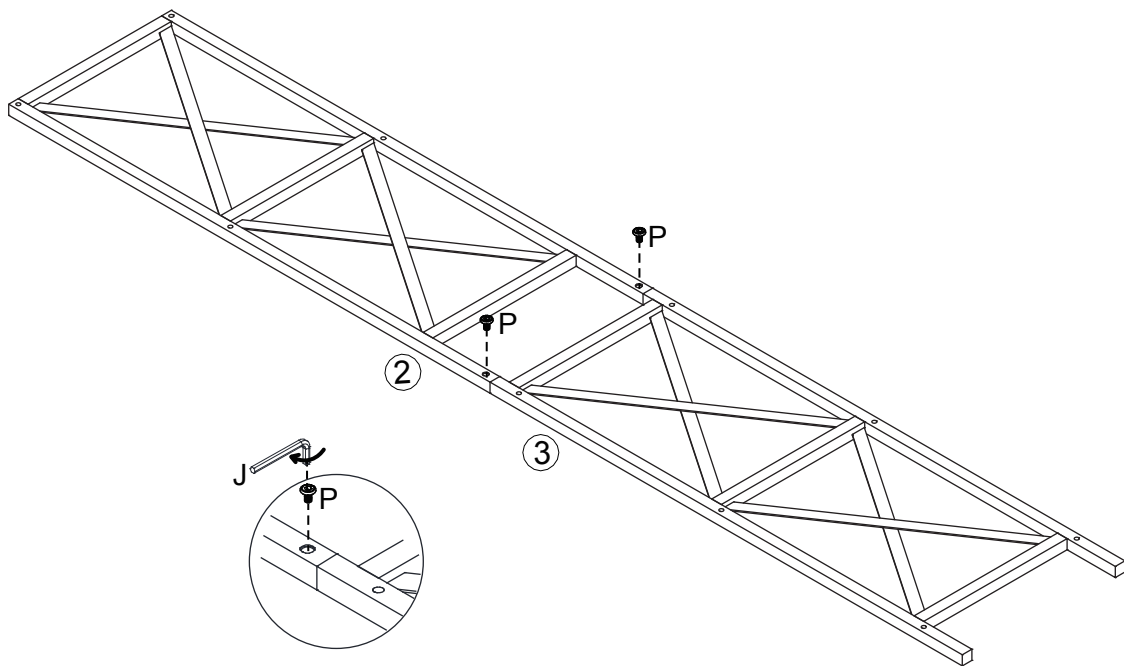

2xP



**Step 3**  
**Étape 3**

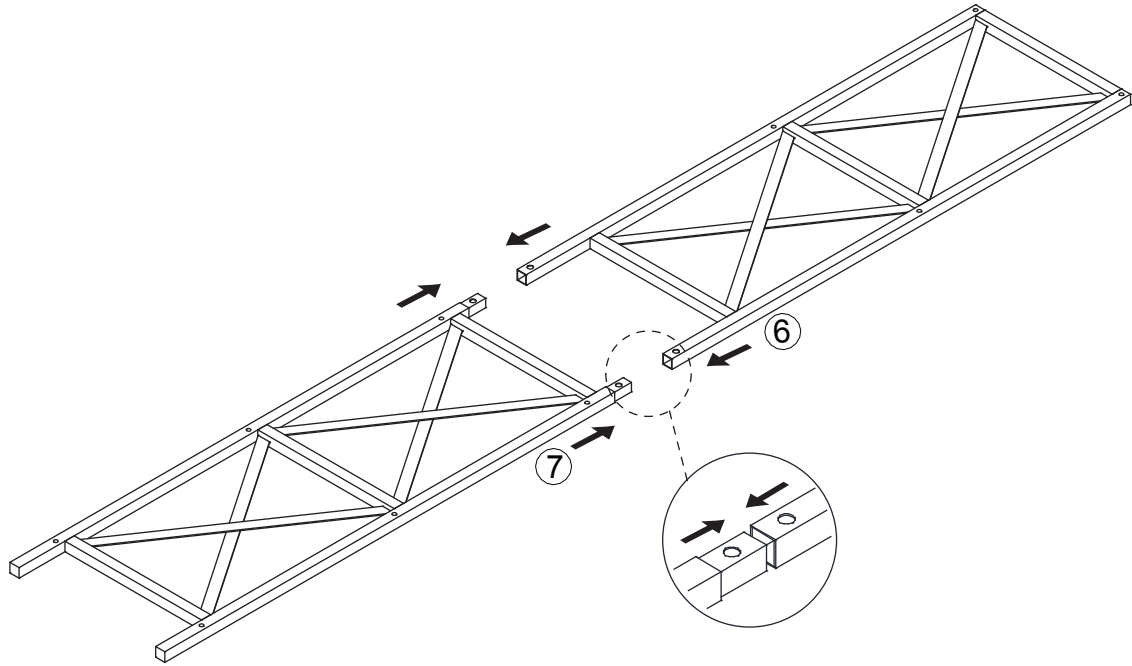

**Step 4**  
**Étape 4**

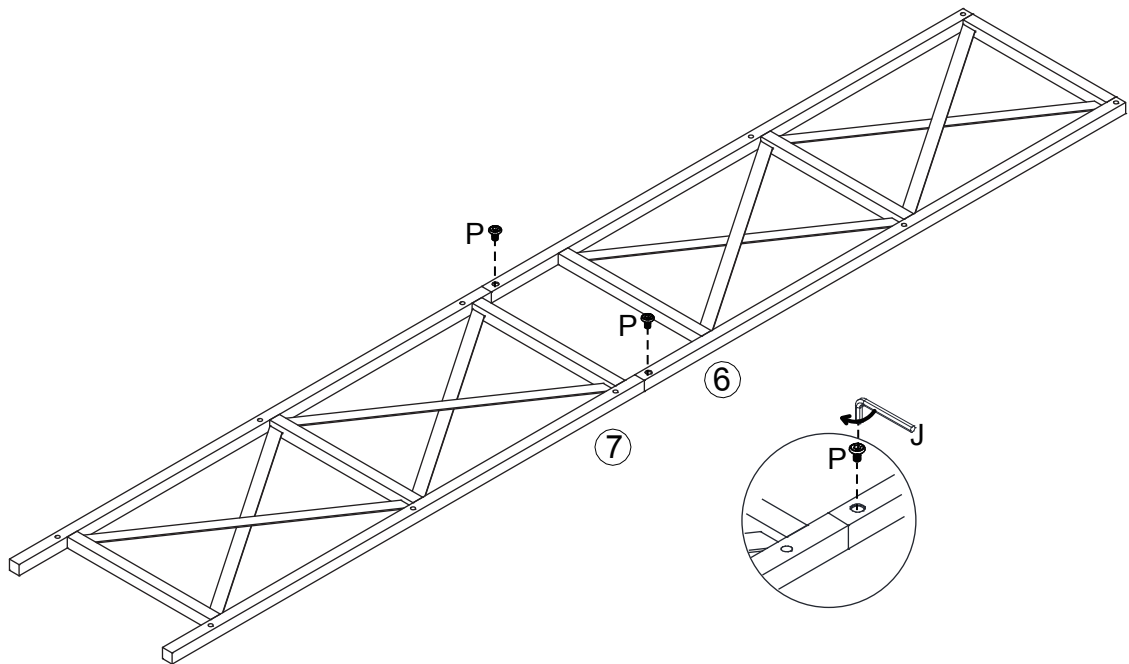

2xP



# Step 5 Étape 5

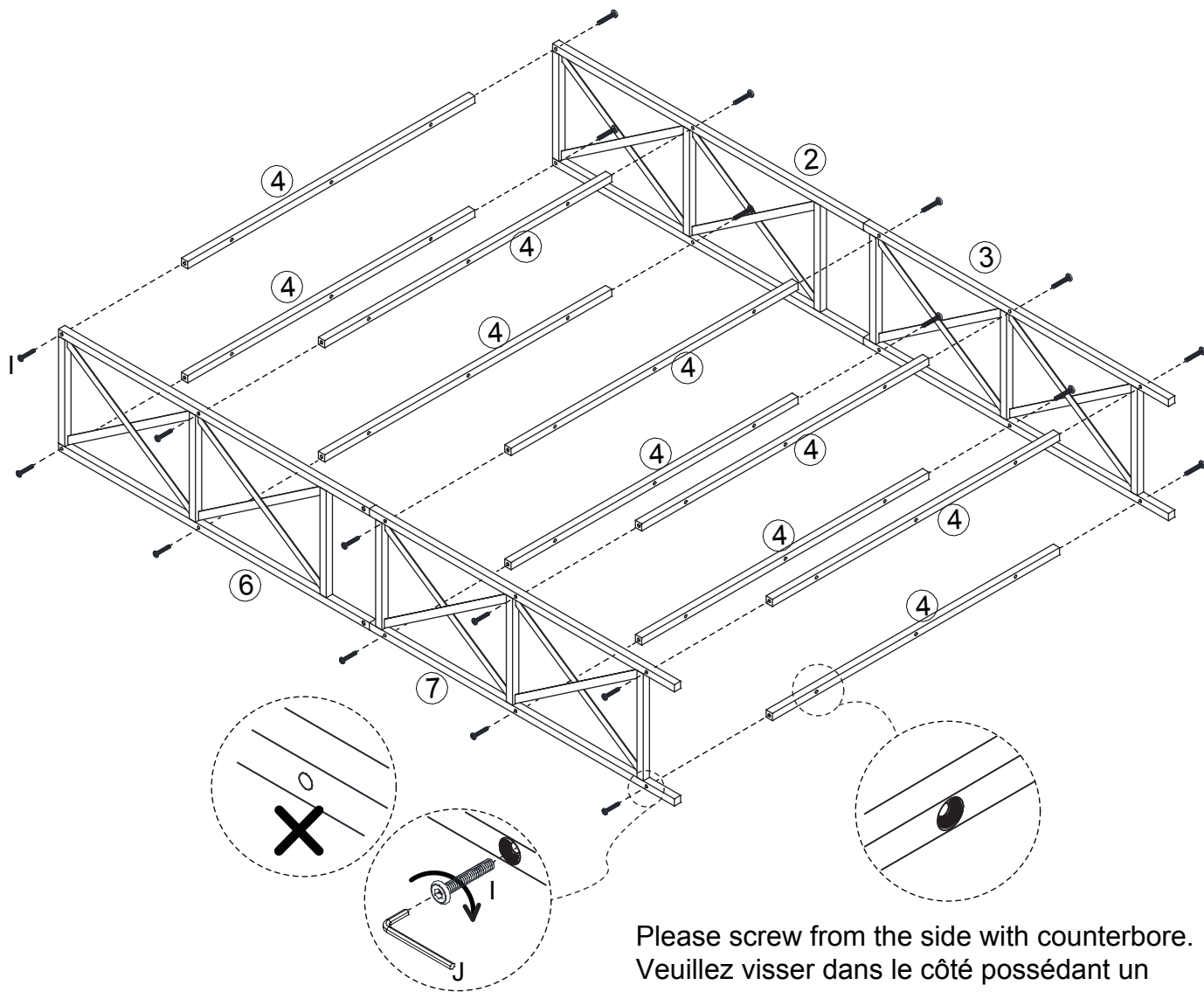



Please screw from the side with counterbore.  
Veuillez visser dans le côté possédant un contre-alésage.

20x1

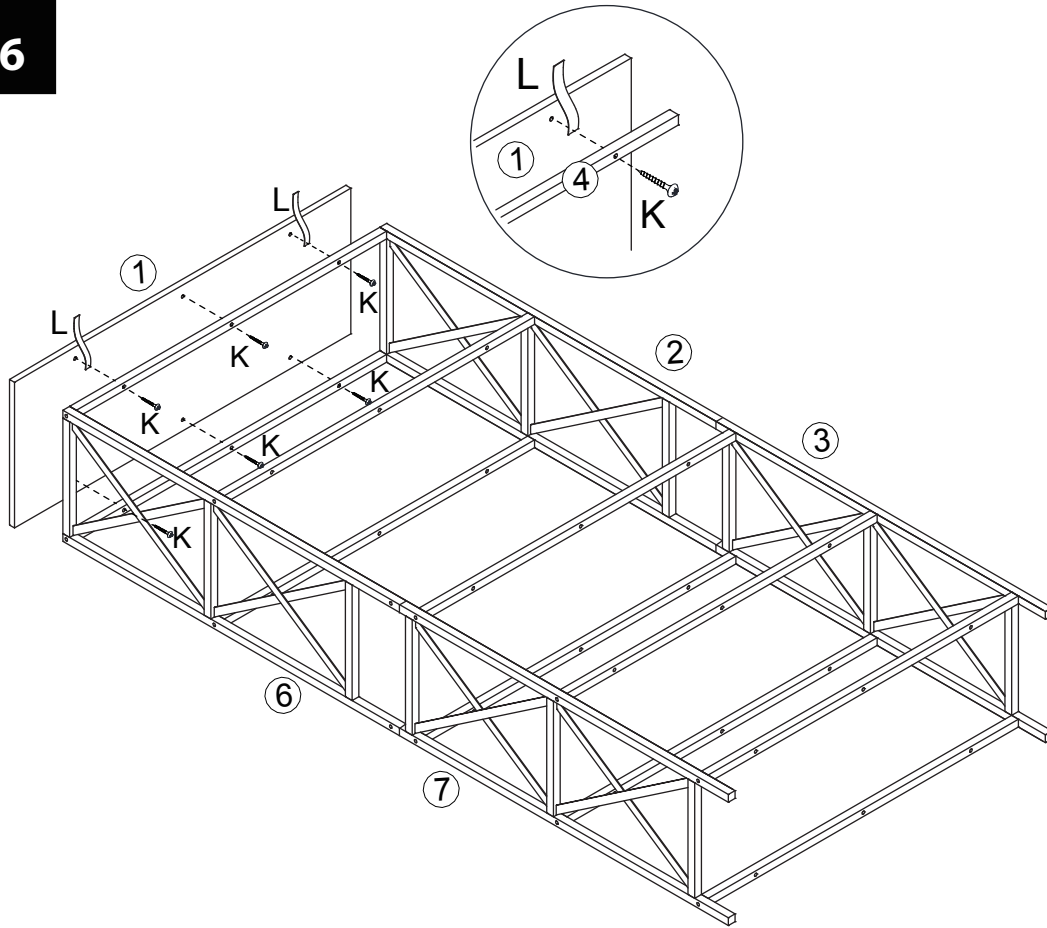

**Step 6**  
**Étape 6**



6xK	
2xL	

**Step 7**  
**Étape 7**

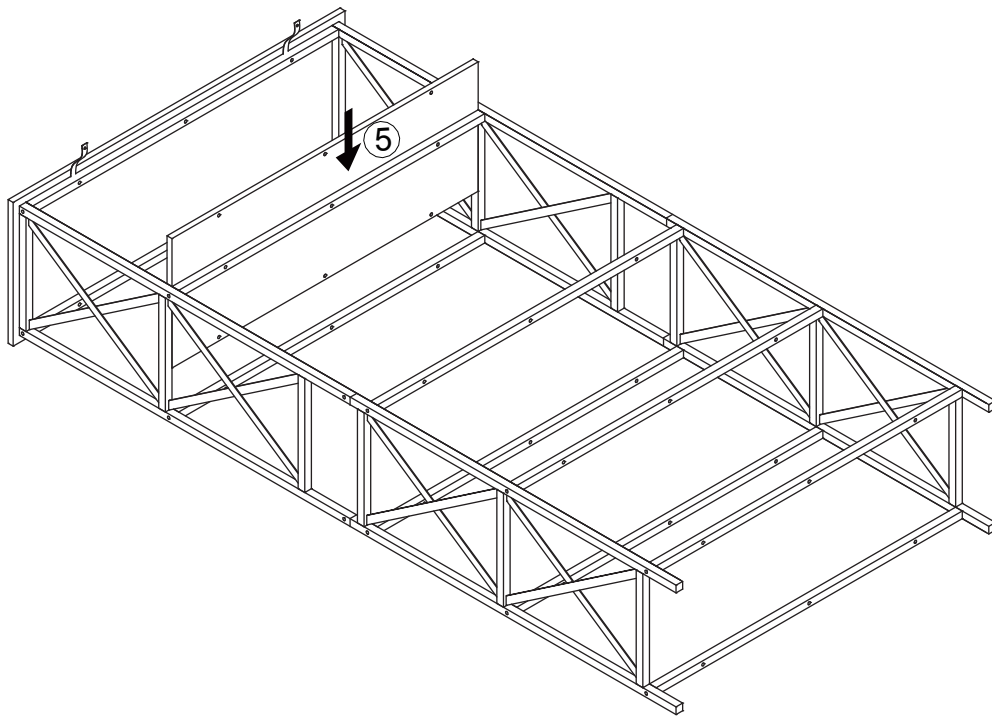

**Step 8**  
**Étape 8**

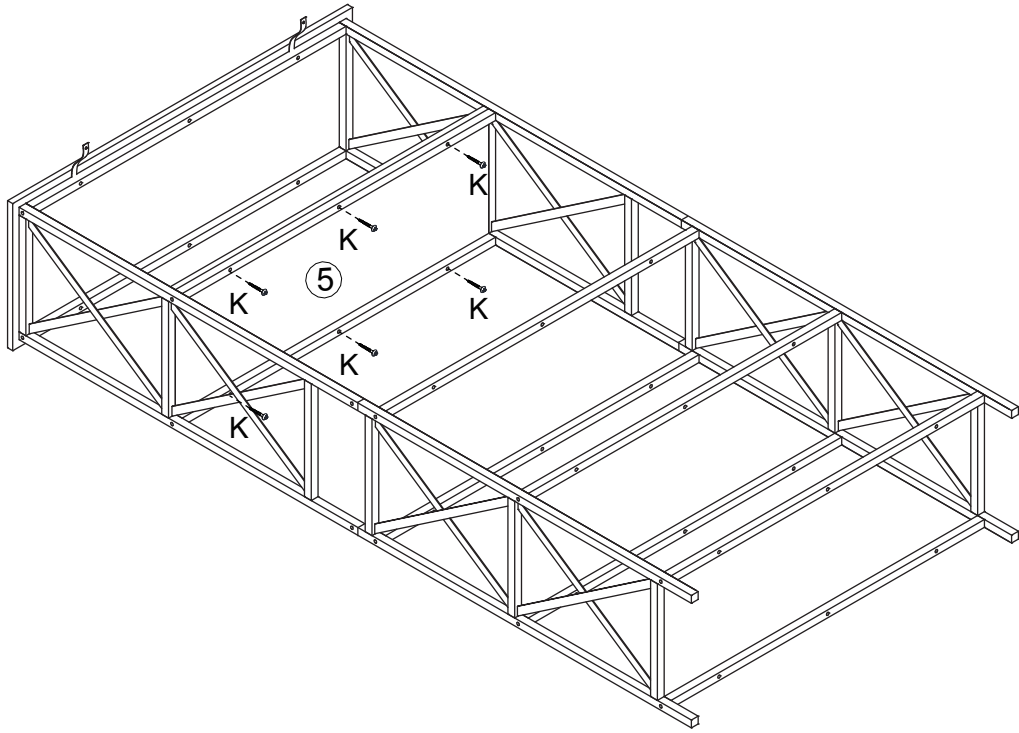

6xK



**Step 9**  
**Étape 9**

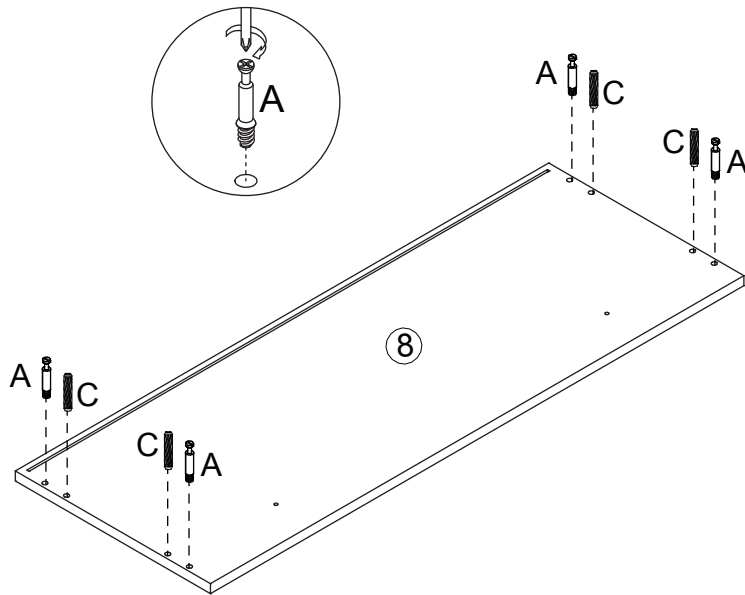

4xA



4xC



**Step 10**  
**Étape 10**

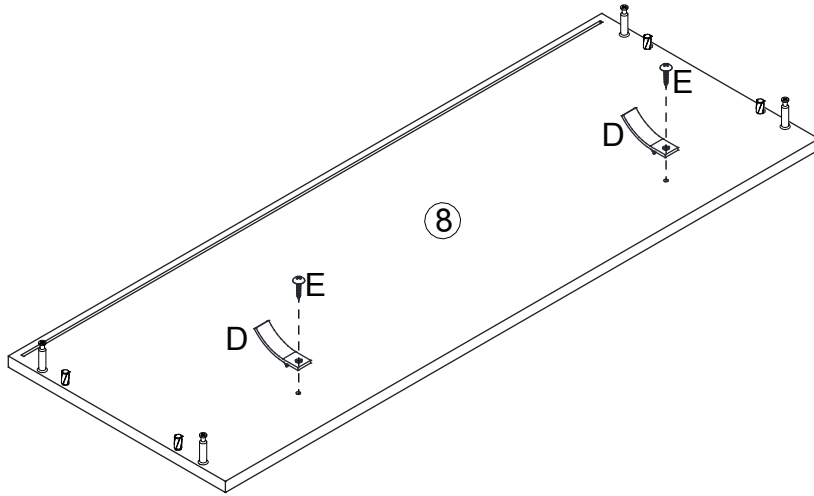

2xD	
2xE	

**Step 11**  
**Étape 11**

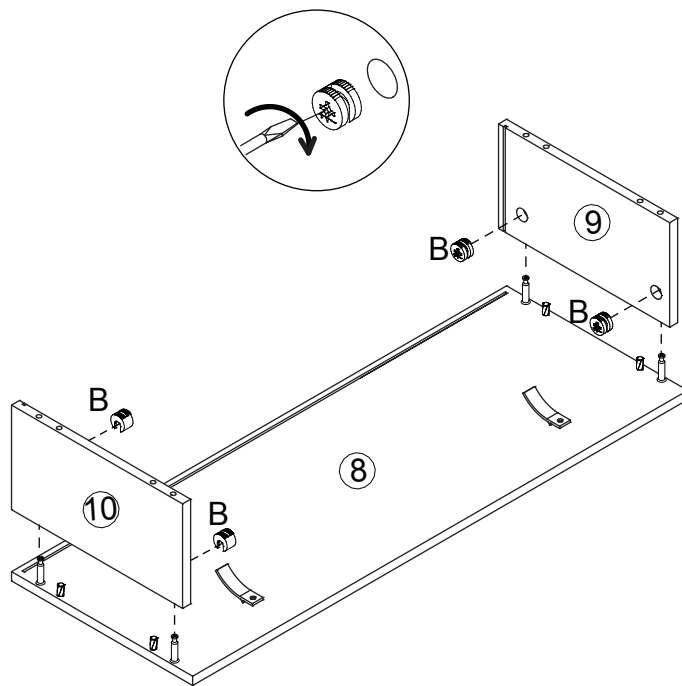

4xB	
-----	--



**Step 12**  
**Étape 12**

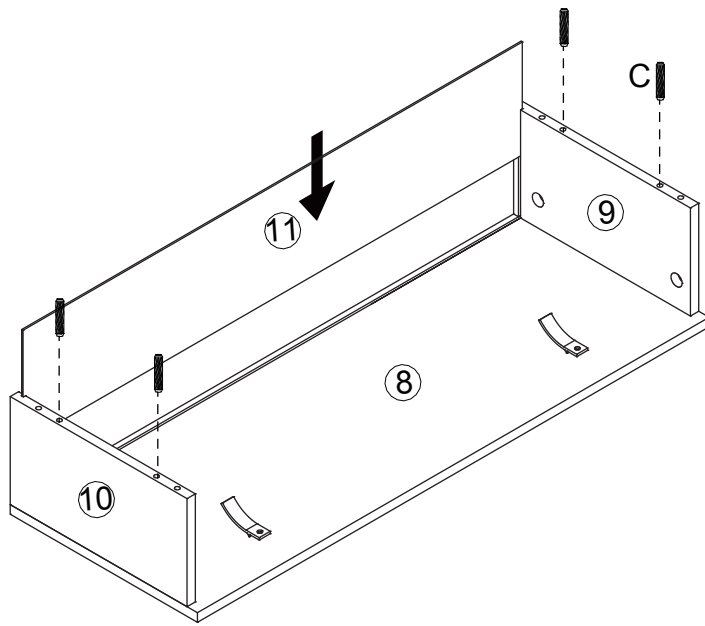

4xC



**Step 13**  
**Étape 13**

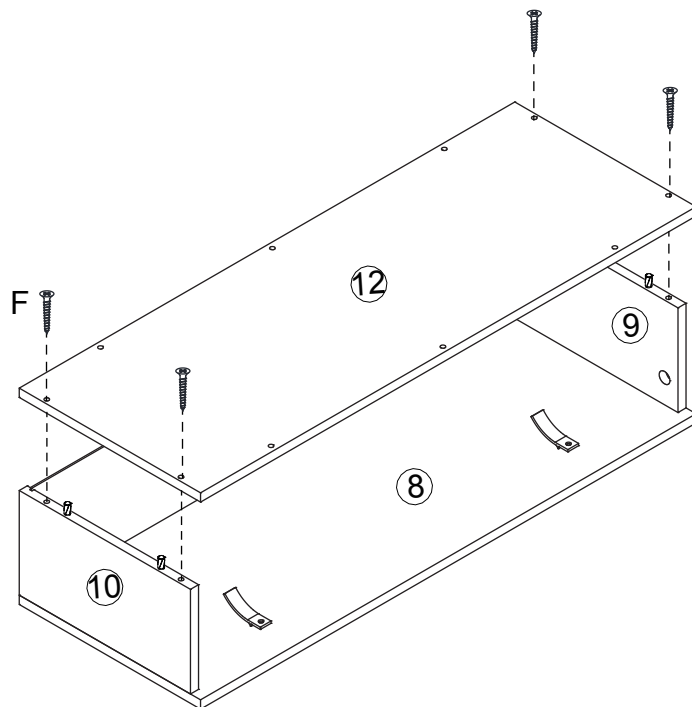

4xF



**Step 14**  
**Étape 14**

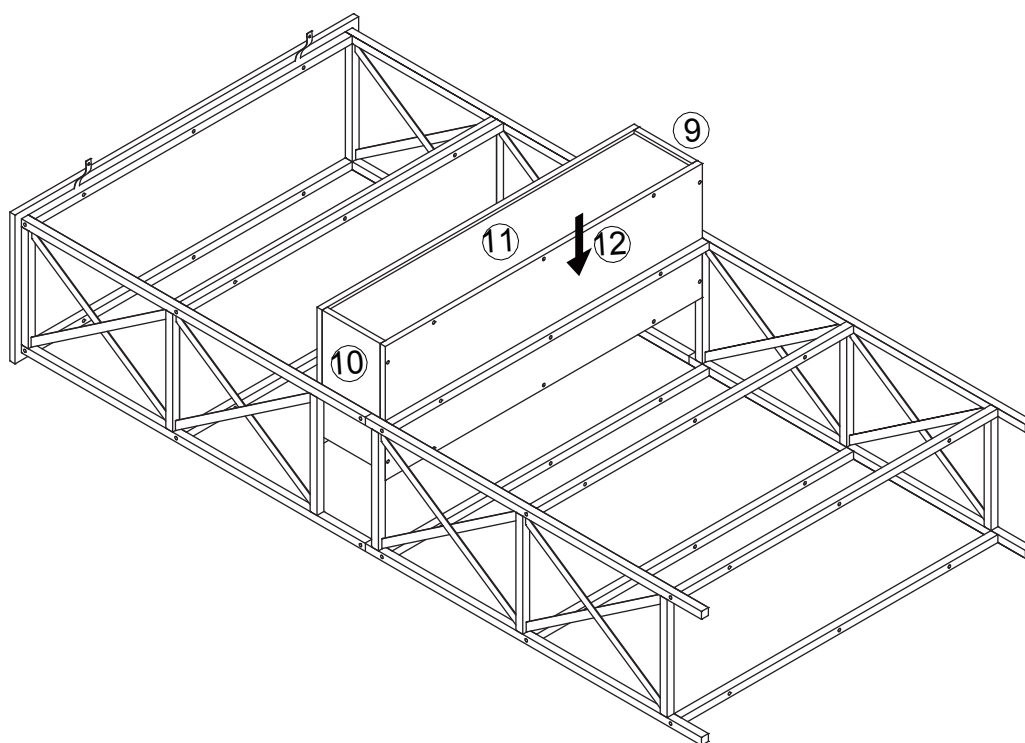

**Step 15**  
**Étape 15**

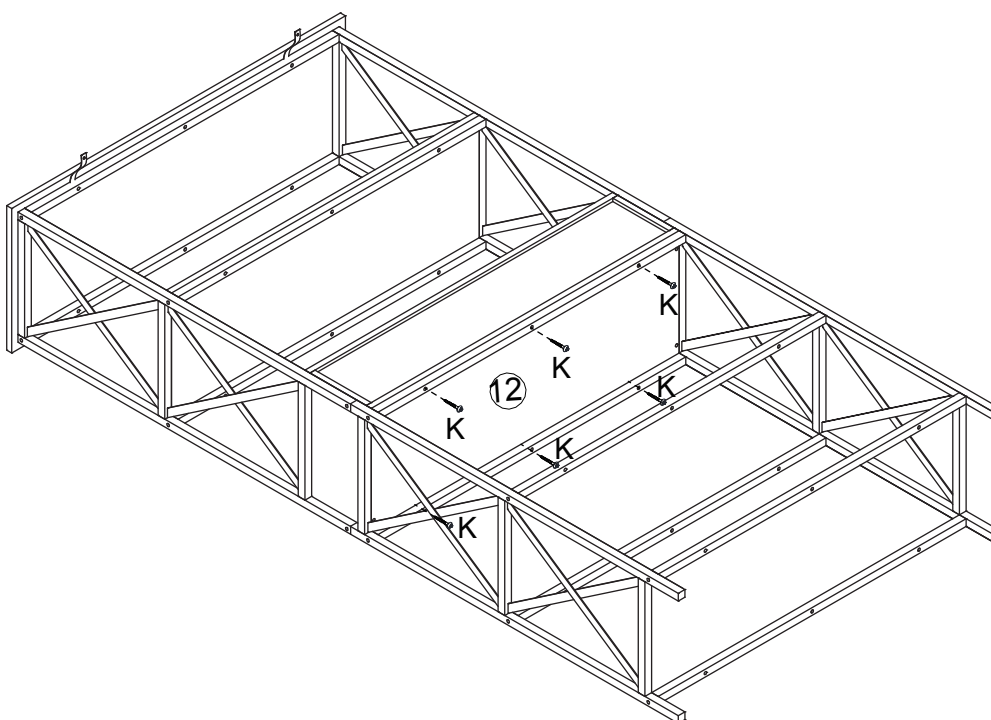

6xK



**Step 16**  
**Étape 16**

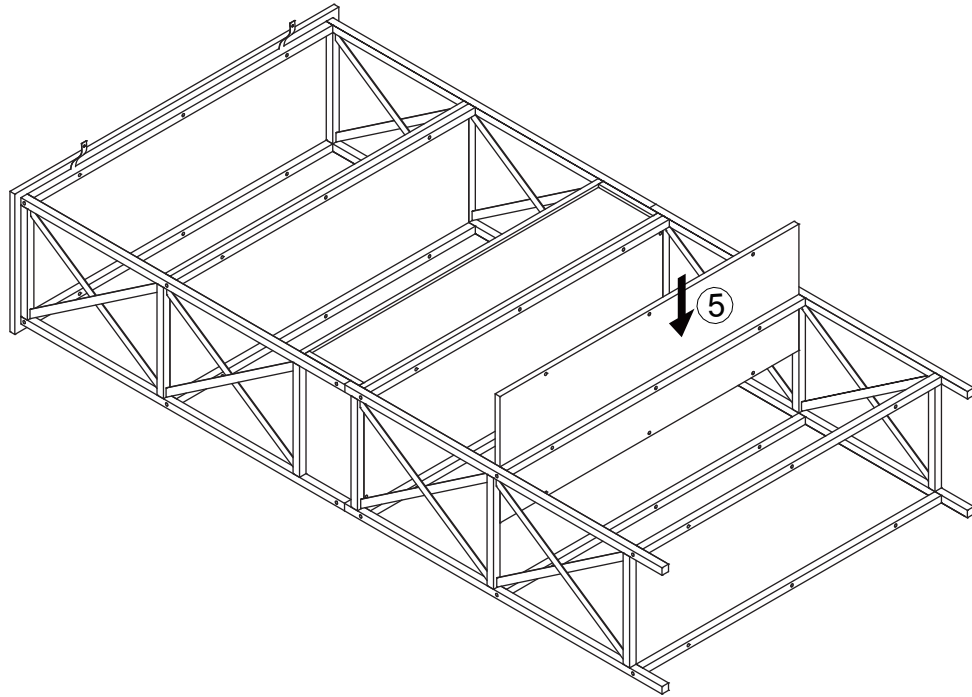

**Step 17**  
**Étape 17**

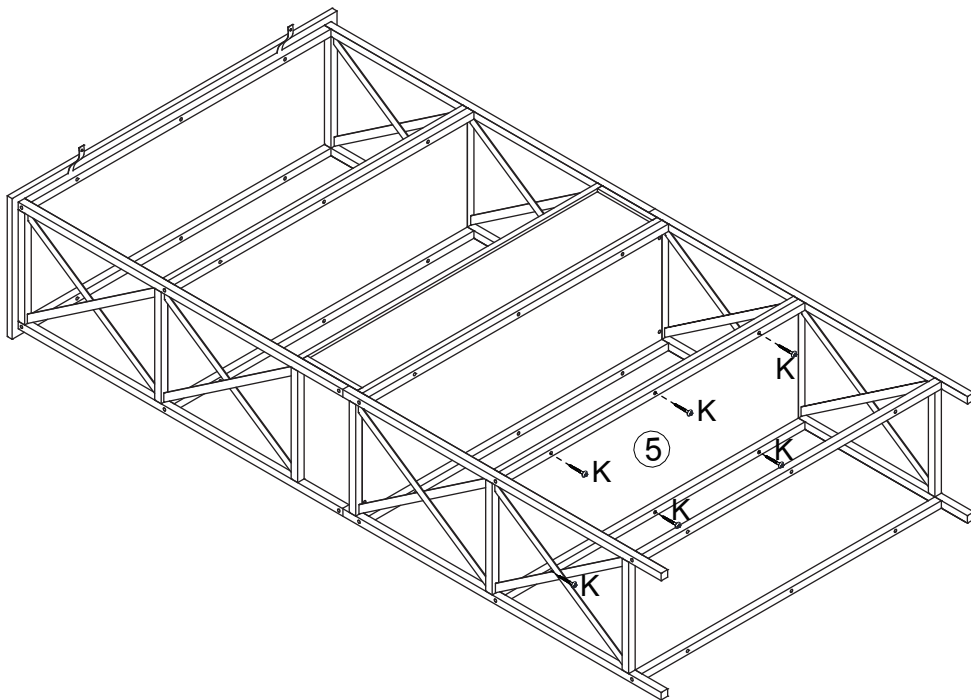

6xK



**Step 18**  
**Étape 18**

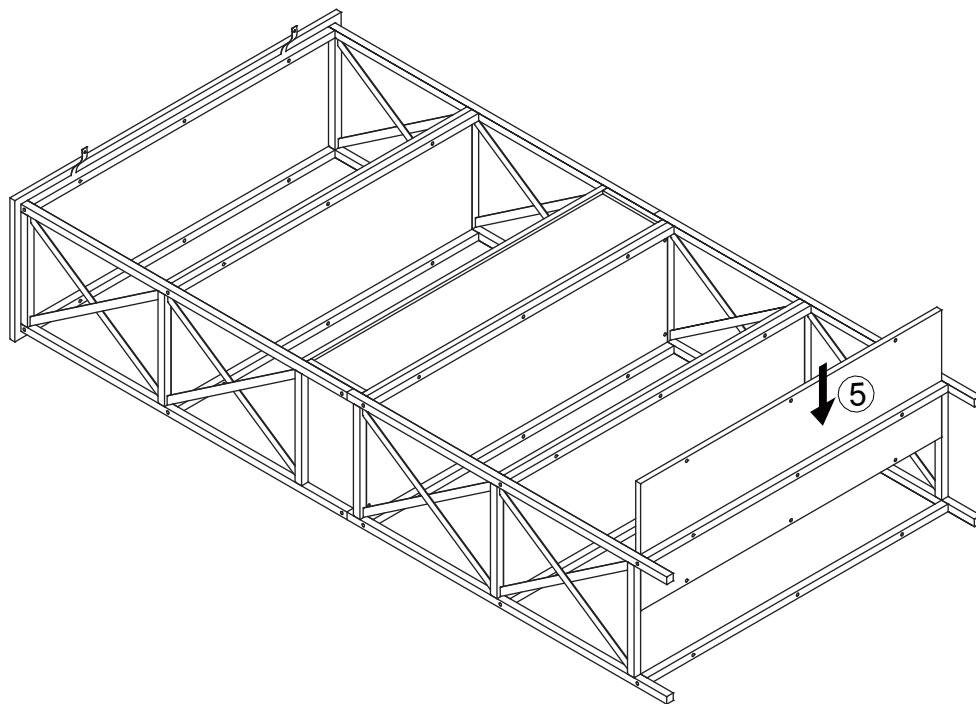

**Step 19**  
**Étape 19**

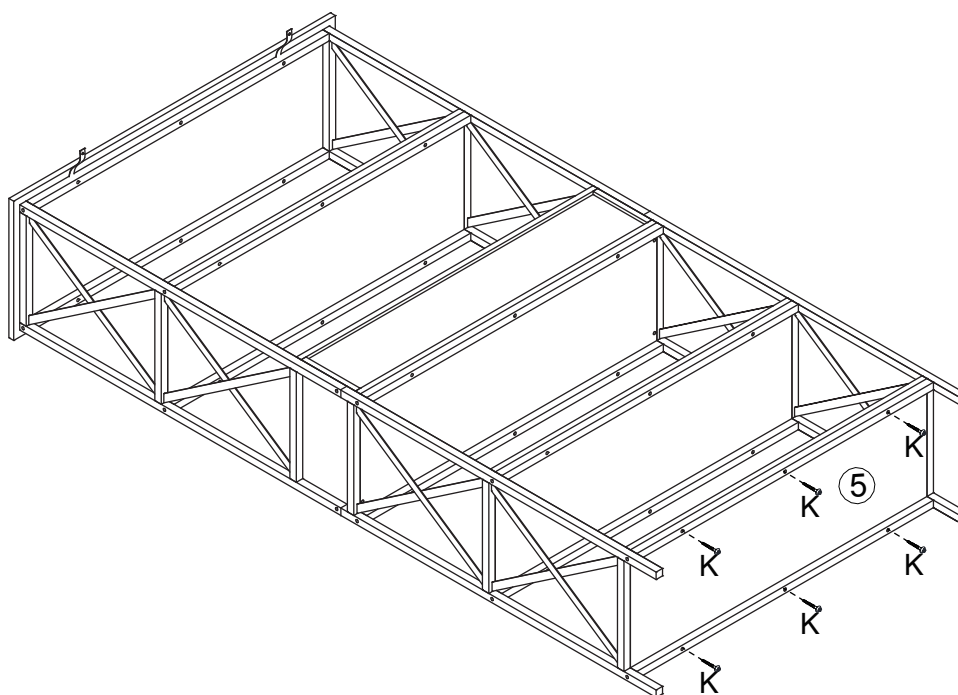

6xK



**Step 20**  
**Étape 20**

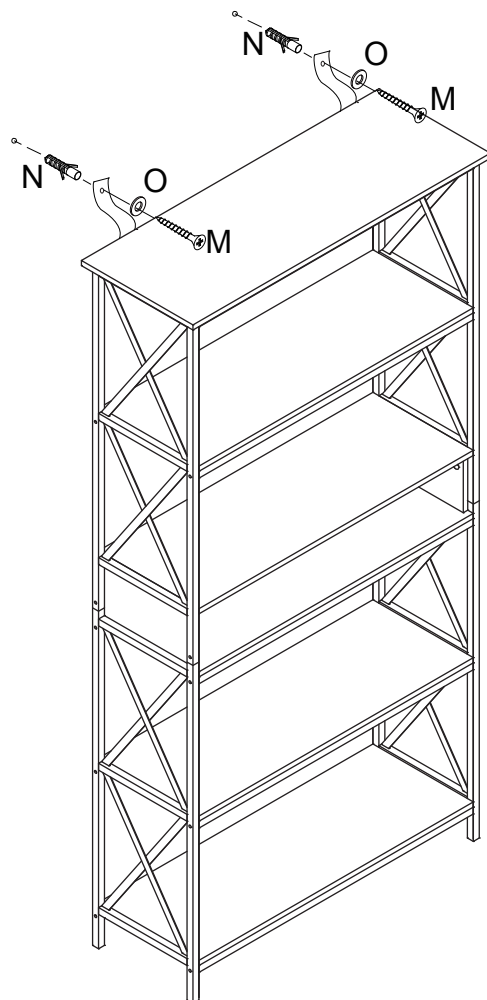

2xM	
2xN	
2xO	

**Step 21**  
**Étape 21**

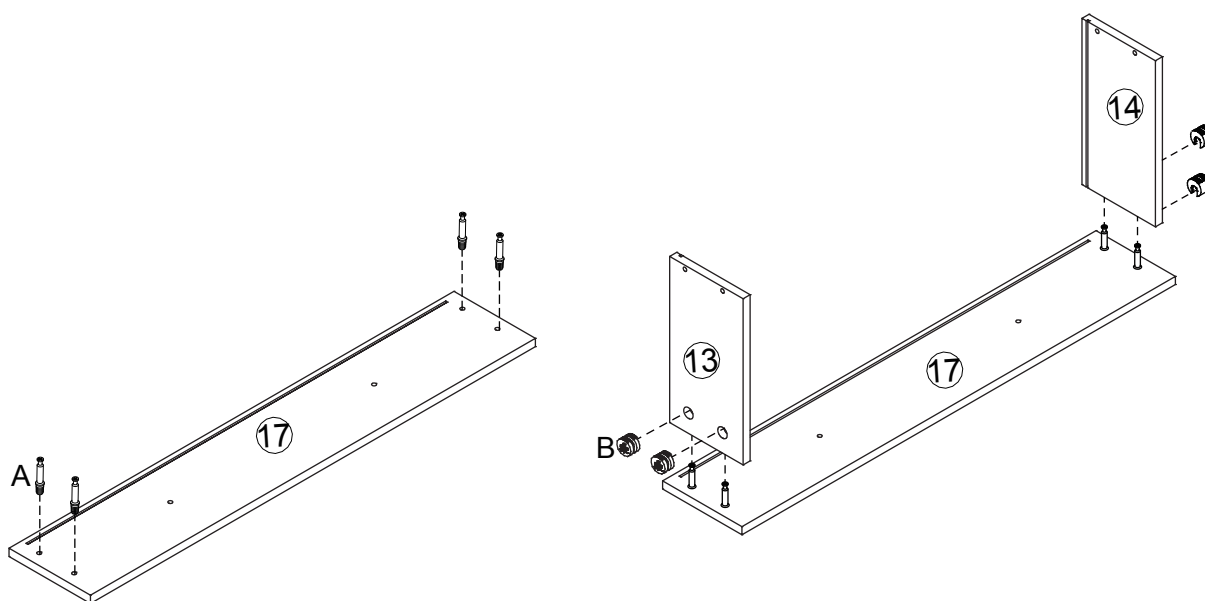

4xA	
4xB	

**Step 22**  
**Étape 22**

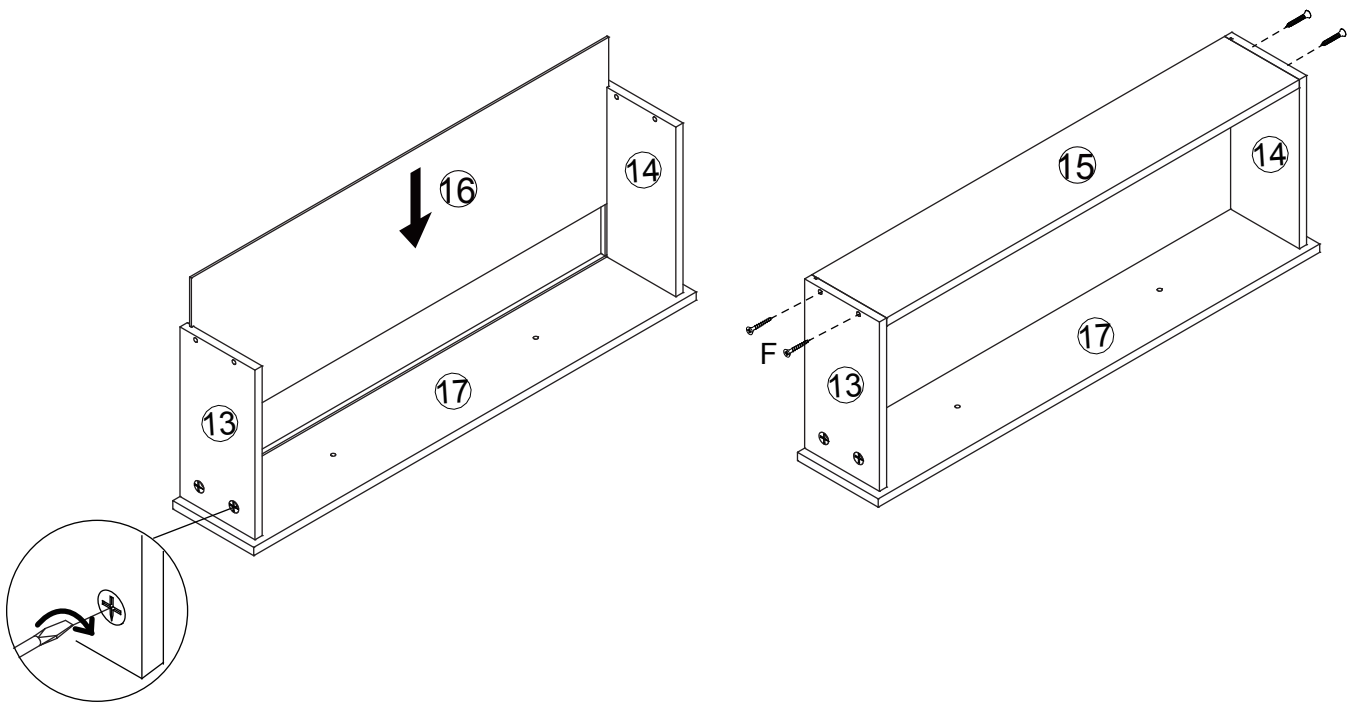

4xF	
-----	--

**Step 23**  
**Étape 23**

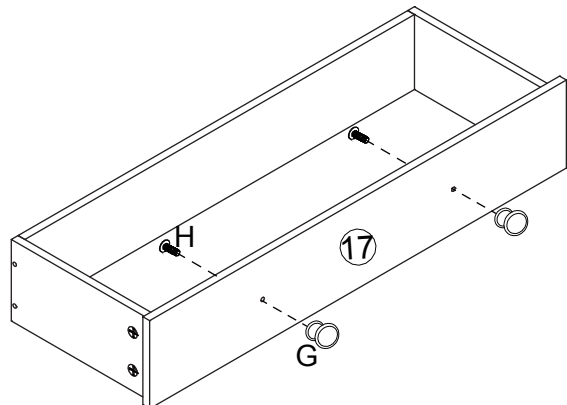

2xG	
2xH	

## Step 24 Étape 24

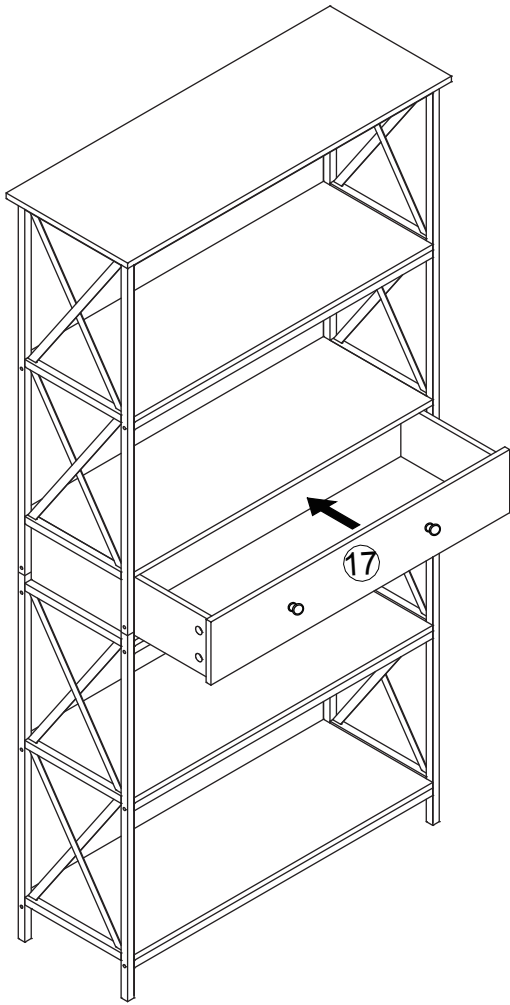

## Step 25 Étape 25

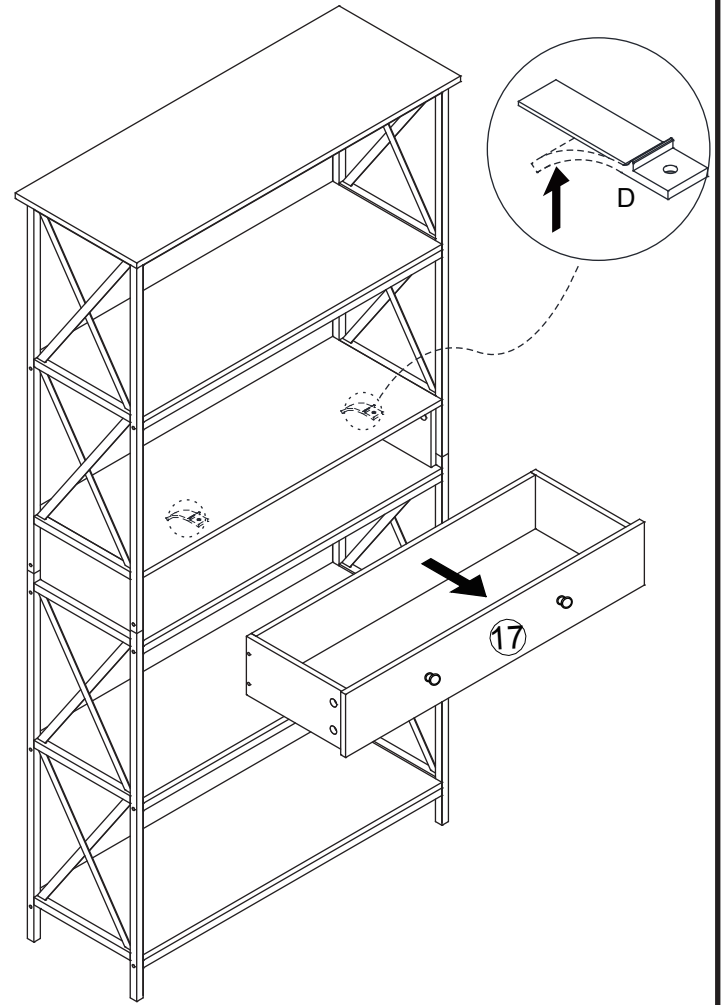

### Warranty

This product carries a one (1) year warranty against defects in workmanship and materials. We agree to replace a defective product free of charge within the stated warranty period, when returned by the original purchaser with proof of purchase. This product is not guaranteed against wear or breakage due to misuse and/or abuse.

### GARANTIE

Cet article comprend une garantie d'un (1) an contre les défauts de fabrication et de matériaux. Nous consentons à remplacer l'article défectueux sans frais au cours de la période de garantie convenue lorsque l'article, accompagné de la preuve d'achat, est retourné par l'acquéreur initial. Exclusion : usure ou bris causés par un usage abusif ou inapproprié.