



SLEEVE AND COLLAR MOUNT FREESTALLS



NEW

Features

- Galvanized or gatorshield loop option
- Heavy galvanized 3 1/2" post
- Easy installation
- Adjustable height
- Cow friendly loop profile
- Available in 79", 85", and 94" long loops.

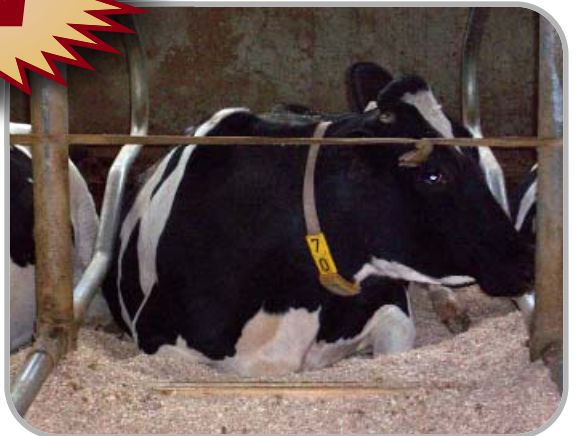

CANARM LTD. - Corporate Office
 2157 Parkedale Ave., Brockville, ON
 Canada K6V 5V6
 Tel: (613) 342-5424 Fax: 1-800-263-4598

CANARM LTD. - USA Warehouse
 808 Commerce Park Drive
 Ogdensburg, New York, USA 13669
 Tel: 1-800-267-4427 Fax: 1-800-263-4598
 Web Site: www.canarm.com
 E-Mail: agsales@canarm.ca

Arthur Manufacturing Facility
 #7686 Concession 16, RR 4 Arthur, ON
 Canada NOG 1A0
 Tel: (519) 848-3910 Fax: (519) 848-3948

SLEEVE & COLLAR MOUNT FREESTALL SINGLE ROW

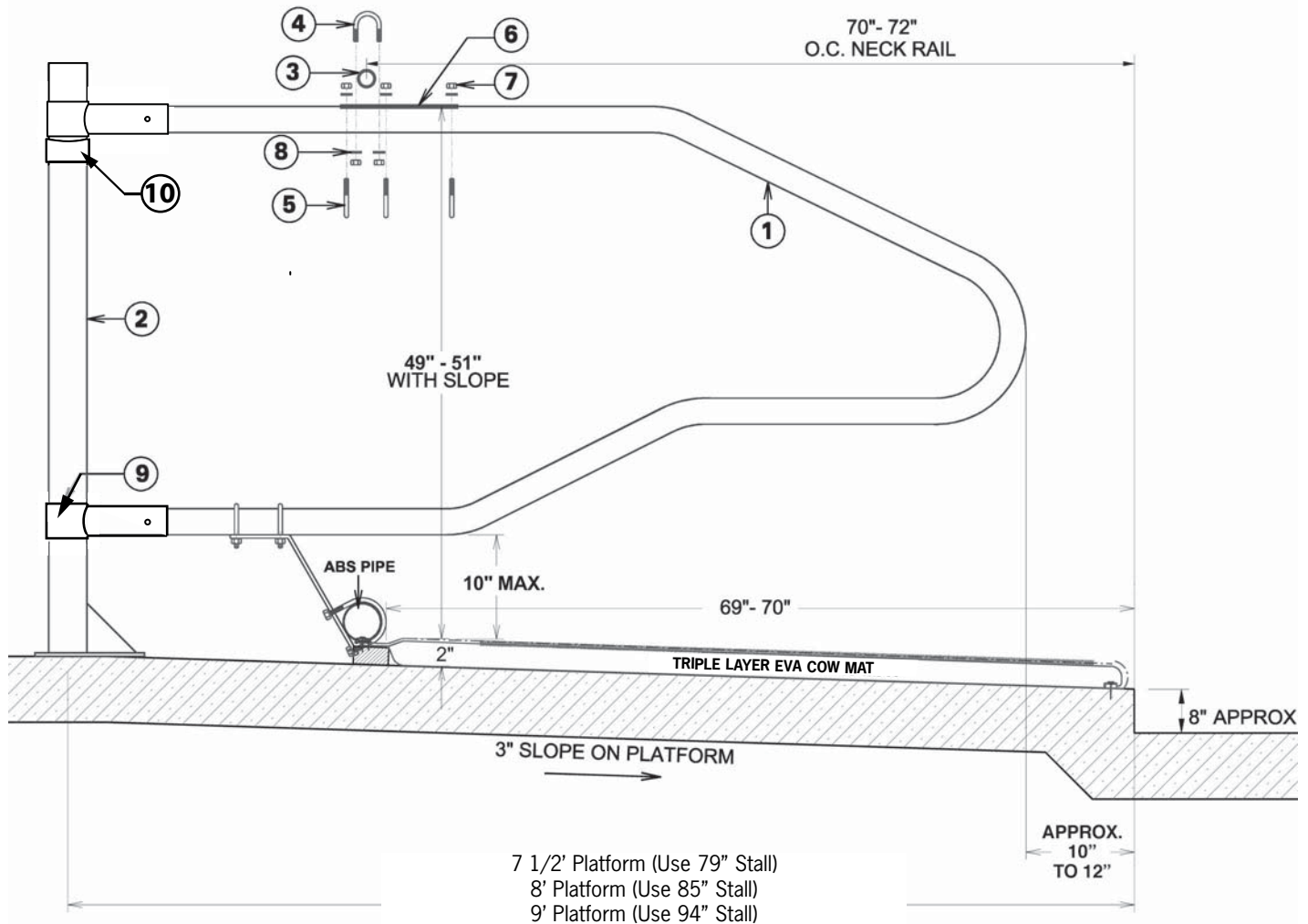

ILLUS.	DESCRIPTION	PART #
1	79" SLEEVE & COLLAR MOUNT FREESTALL (39" HIGH) (9" OFFSET) - NO PLATE	1012307N
1	85" SLEEVE & COLLAR MOUNT FREESTALL (39" HIGH) (9" OFFSET) - NO PLATE	1012308N
1	94" SLEEVE & COLLAR MOUNT FREESTALL (39" HIGH) (9" OFFSET) - NO PLATE	1012309N
2	POST 56" (3.5" OD .150 WALL) (16' - 20' SPACING) BOLT DOWN	1012491
N/S	POST 64" (3.5" OD .150 WALL) CEMENT IN	1012490
3	1 1/4" STD. HEADRAIL PIPE - 21 FT. LENGTH	1110400-1
4	U-BOLT 1.75" ID X 2 3/8" LG.	X-OVER 2 3/8" X 1 5/8" (10" PL + 5 U-BOLTS) 101169-10
5	U-BOLT 3/8", 2.5" ID X 3.25" LG.	
6	X-OVER PLATE ONLY 5" X 10"	
7	3/8" LOCK NUT	
8	3/8" WASHER	
9	GALV. SINGLE MOUNT 2/STALL	1012300S
10	BOLT ON COLLAR	1440009CB

FOR INFORMATION ON BRISKET BRACKET, ABS PIPE & ACCESSORIES SEE FREESTALLS-18

SLEEVE & COLLAR MOUNT FREESTALL DOUBLE ROW

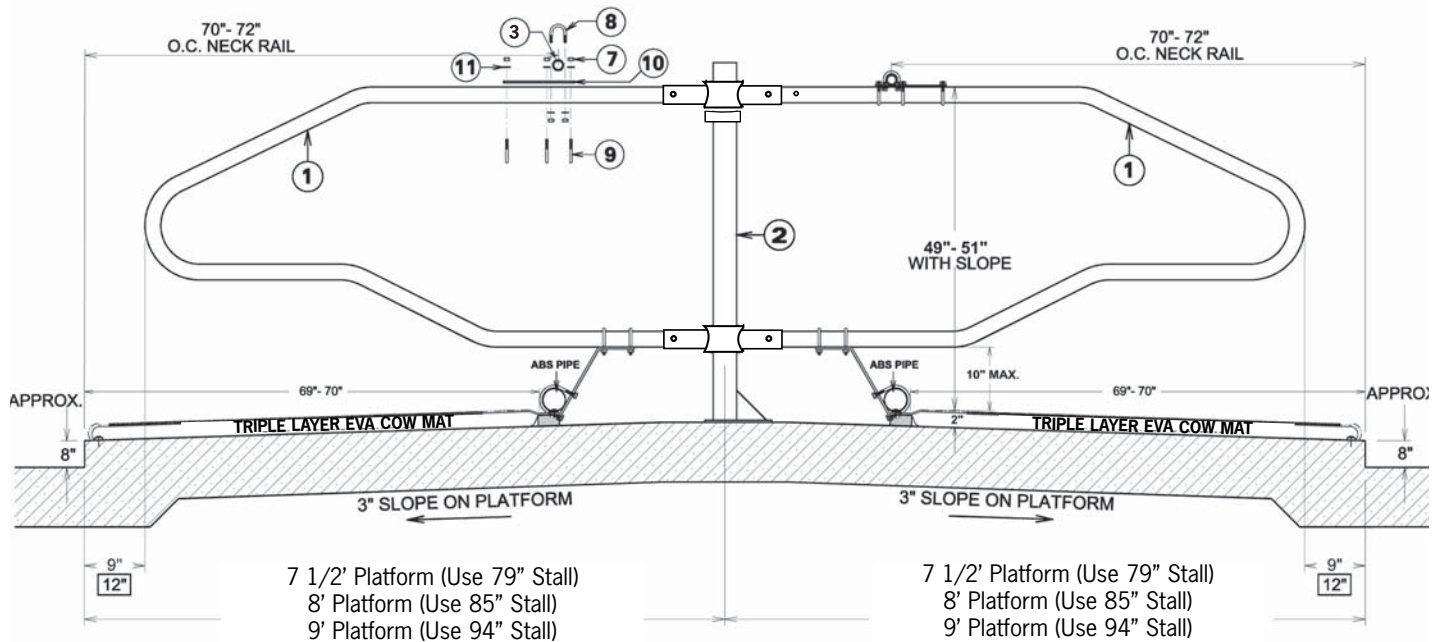

ILLUS.	DESCRIPTION	PART #
1	79" SLEEVE & COLLAR MOUNT FREESTALL (39" HIGH) (9" OFFSET) - NO PLATE	1012307N
1	85" SLEEVE & COLLAR MOUNT FREESTALL (39" HIGH) (9" OFFSET) - NO PLATE	1012308N
1	94" SLEEVE & COLLAR MOUNT FREESTALL (39" HIGH) (9" OFFSET) - NO PLATE	1012309N
	POST 56" (3.5" OD .150 WALL) BOLT DOWN	1012491
N/S	POST 64" (3.5" OD .150 WALL) CEMENT IN	1012490
3	1 1/4" STD. HEADRAIL PIPE - 21 FT. LENGTH	1110400-1
4	GALV. DBL MOUNT/STALL	1012300D
5	BOLT ON COLLAR	1440009CB
8	U-BOLT 1.75" ID X 2 3/8" LG. (20-6A)(20 pcs./PKG)	X-OVER 2 3/8" X 1 5/8" (10" PL + 5 U-BOLTS) 101169-10
9	U-BOLT 3/8", 2.5" ID X 3.25" LG. (20-5A)(30 pcs./PKG)	
10	X-OVER PLATE ONLY 5" X 10" (10 pcs./PKG)	
7	3/8" LOCK NUT (100 pcs./PKG)	
11	3/8" WASHER (100 pcs./PKG)	

FOR INFORMATION ON BRISKET BRACKET, ABS PIPE & ACCESSORIES SEE FREESTALLS-18